

HWS AG
 95.001.0043
 18.5/10 x 23 x 8
 n max. 18'000
 MAN
 MEL 32mm

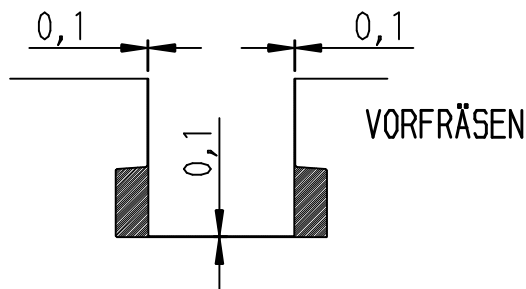
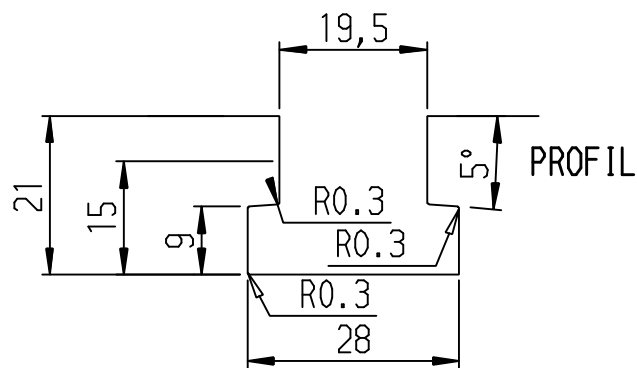
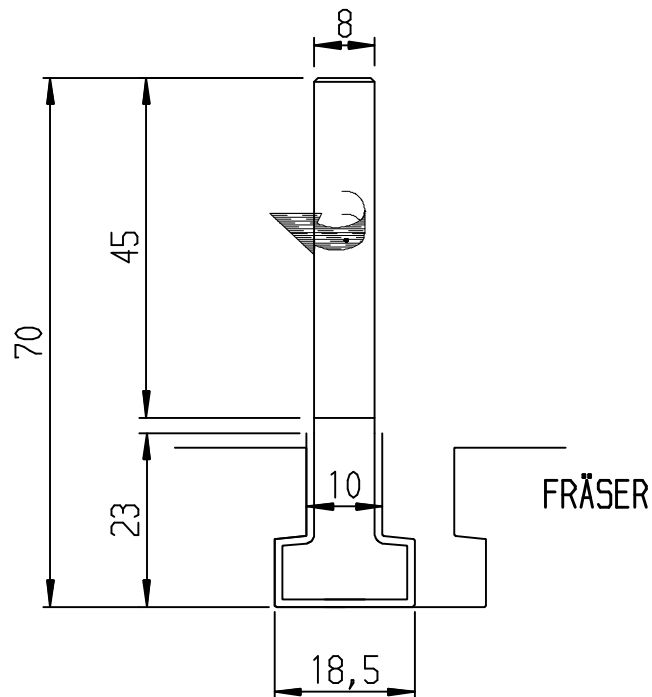
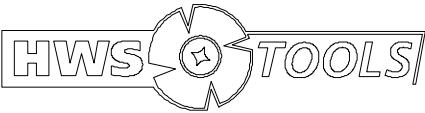

HW / Z2

		OPO OESCHGER AG			
		HWT-NUTFRÄSER 5°			
Bearbeiter	Datum	PROJEKT	ZCHNR	Version	
Name A. Guggisberg	18-07-2023	95.001.	95.001.0043	1	
Geprüft	Datum	A4 Maßstab	TYPE	Blatt	
Name M. Vogelmann	18-07-2023	1:1	M	1 von 1	