

PLANUNGSHINWEISE

Alle Maße in Millimeter

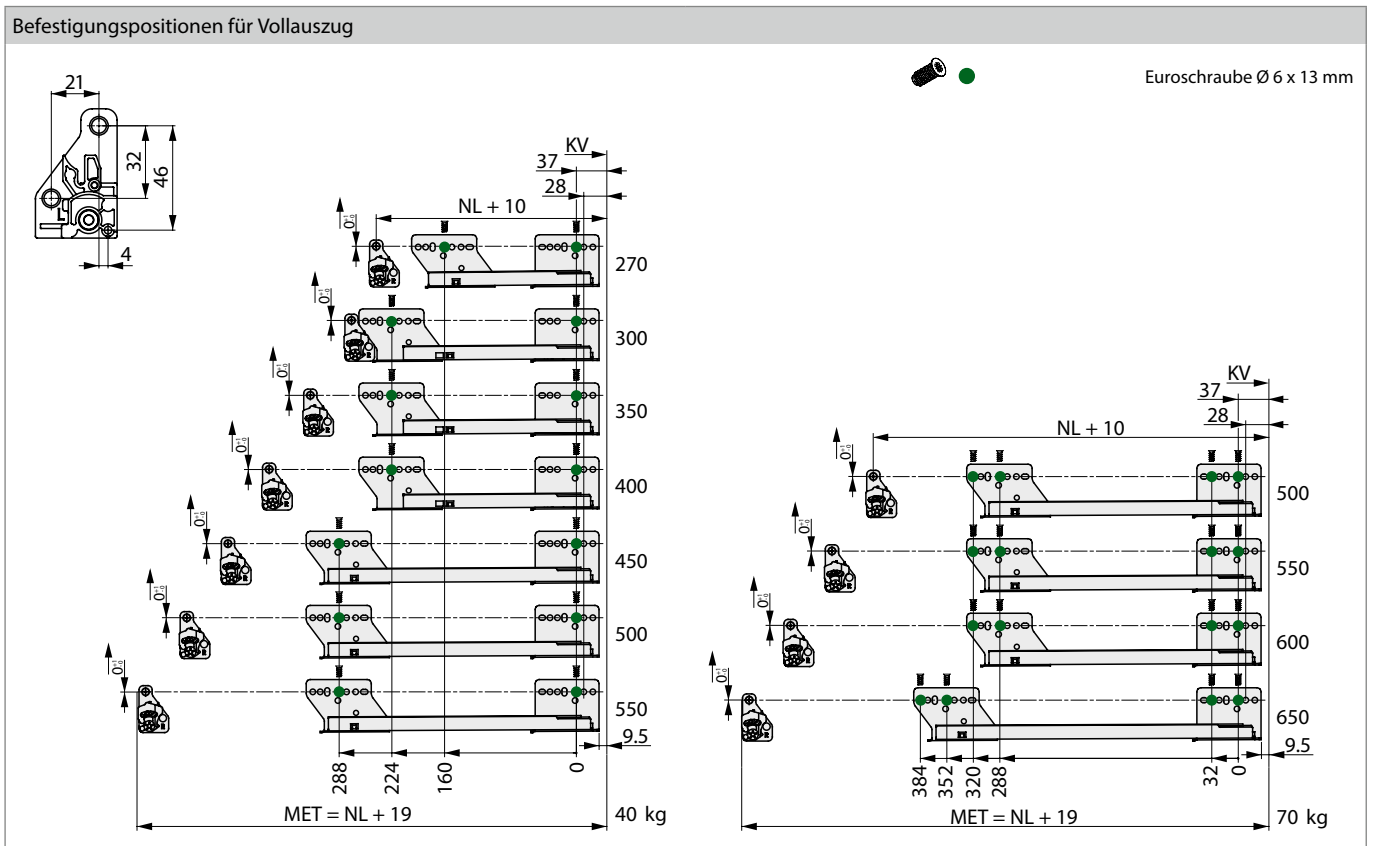
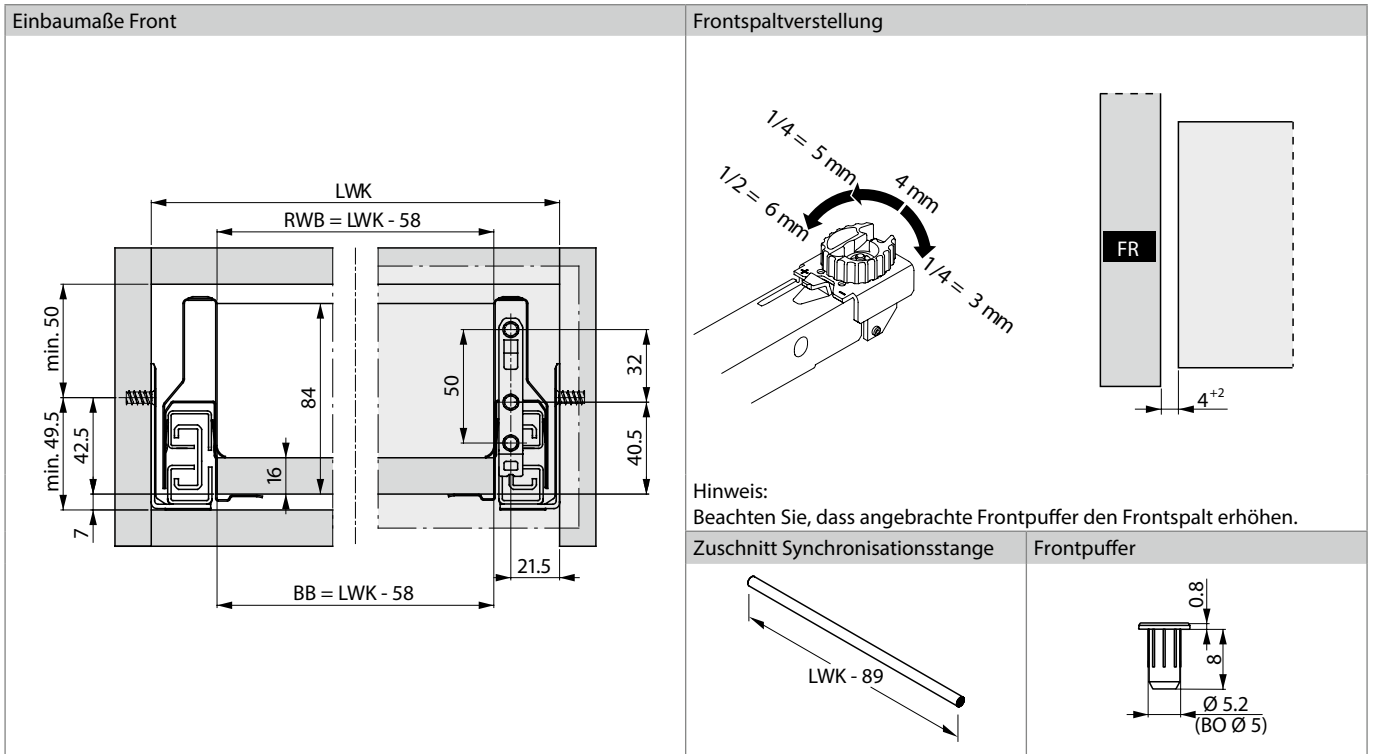

LEGENDE

| | | | | | |
|----|--------------|-----|---------------------|-----|----------------|
| BB | Bodenbreite | KV | Korpusvorderkante | RWB | Rückwandbreite |
| BO | Bohrung | LWK | Lichte Weite Korpus | | |
| FR | Front | MET | Mindesteinbautiefe | | |
| KB | Korpusbreite | NL | Nennlänge | | |