

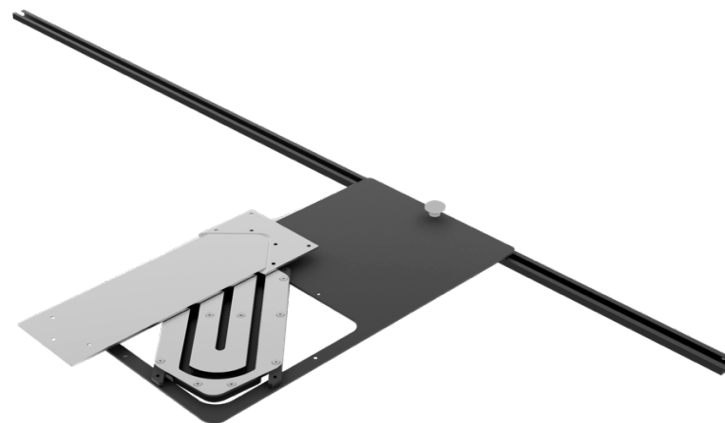

Slider

Installation instruction

- model 450 mm – Article No 1011
- model 550 mm – Article No 5222502
- model 600 mm – Article No 1013
- model 650 mm – Article No 1014
- model 700 mm – Article No 1015



In collaboration with
OPO OESCHGER

A) Content and technical details

Slider mechanism (with pre-installed wheelers and gliders)

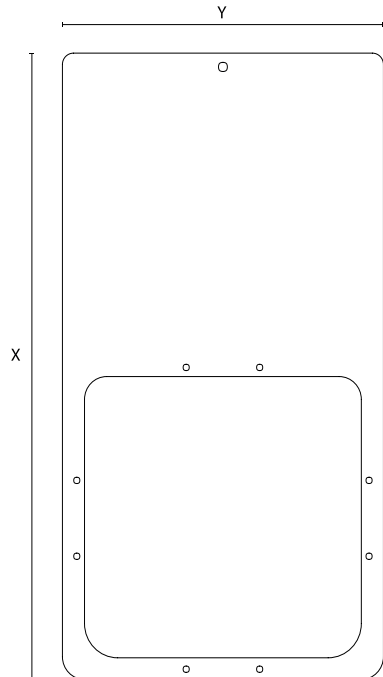

Model	X (mm)	Y (mm)
450	446.5	237.5
550	549	290.5
600	574	290.5
650	599	290.5
700	624	290.5

Sliding bar



Dimensions:
W 28 mm, H 15mm, L 1500mm or 2000mm

Table rotation mechanism (pre-installed)

CM3040

or

CM4070

(with 450 mm model)

(with 550, 600, 650 and 700 mm models)

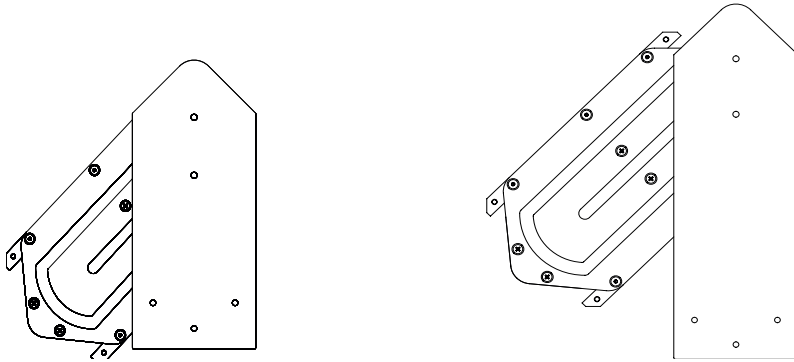

Locking plate for table rotation mechanism

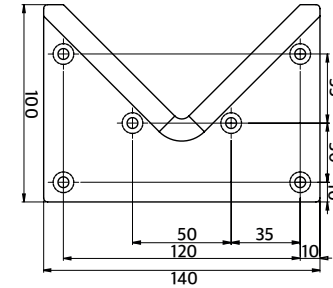

1x fixing screw with plastic stopper

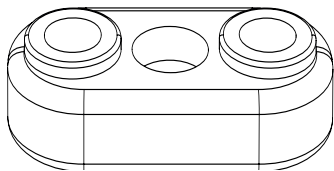
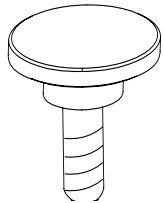

2x plastic stopper with 2x screws and 2x washer

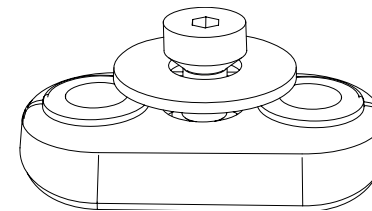

1x plastic felt glider set

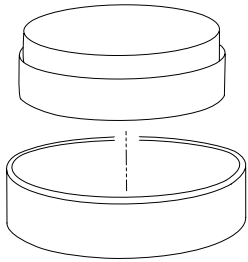

1x plastic felt glider set with space rings and M4x 16 mm (*pre-installed*)

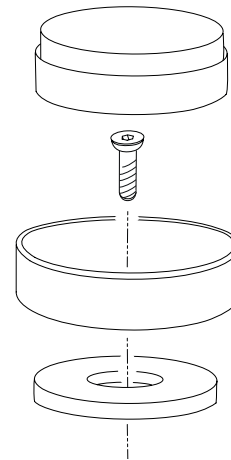

14x 5x 20 mm wood screws

10x M5x 10 mm screws

1x 4x 15 mm screw

Technical details

Applicable width of desk (w): 450, 550, 600, 650 and 700 mm

Minimum thickness of upper rotating desk (t): 38 mm

Gap between furniture and upper desk for rotation (g): 9.8 mm

Material: Steel, Plastic

B) Installation options

The mechanism can be installed in two ways, so that your desk either opens to the left or right. Installation between left and right can be changed any time. Please follow the installation steps accordingly.

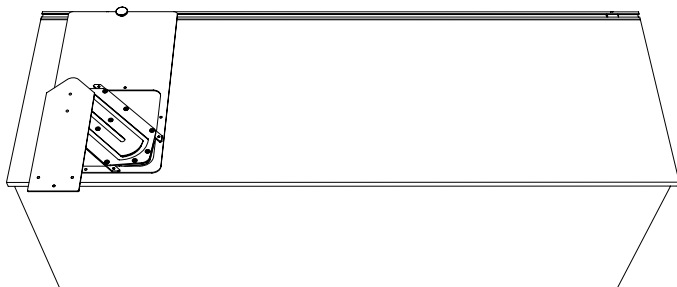
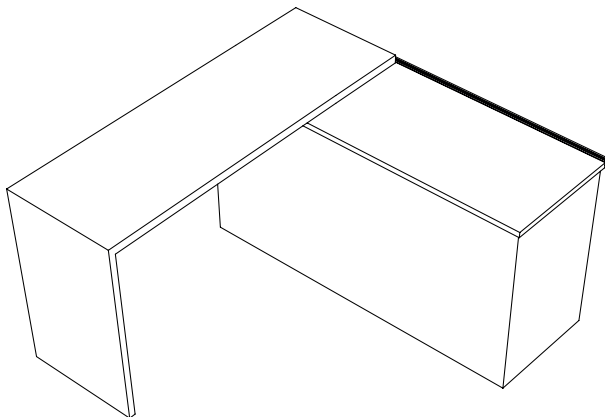

Left opening

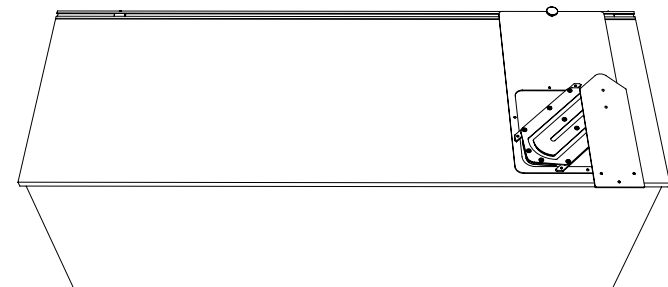
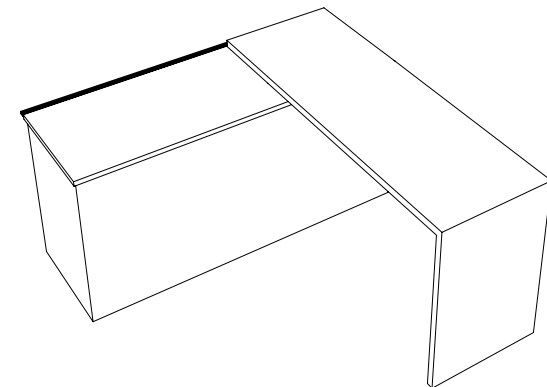

Right opening

C) Installation Steps

1. Mill the below form into the underside of the rotating desk. For measurements and details refer to drawing and 3D STEP file (download available from product page in webshop - www.casetur.com).

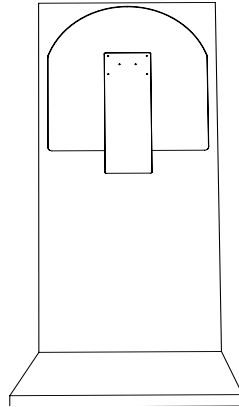

2. Install slider bar at rear of furniture with 2x 5x 20 mm wood screws, one on each side. Align the top of the sliding bar with the upper surface of the furniture base.

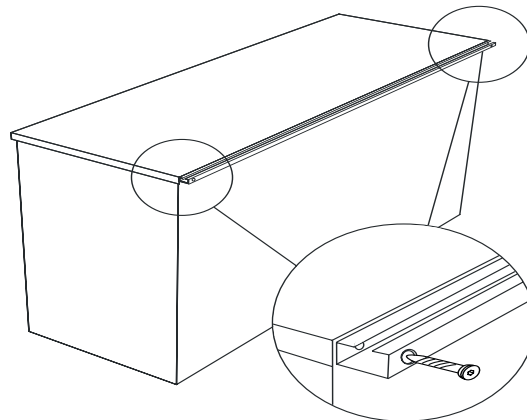

3. Choose your preferred option, left or right opening. The mechanism and felt glider are pre-installed for Left opening. For right opening unscrew the 4x M5 screws from underneath and then install table rotation mechanism for right opening into slider mechanism as shown below.

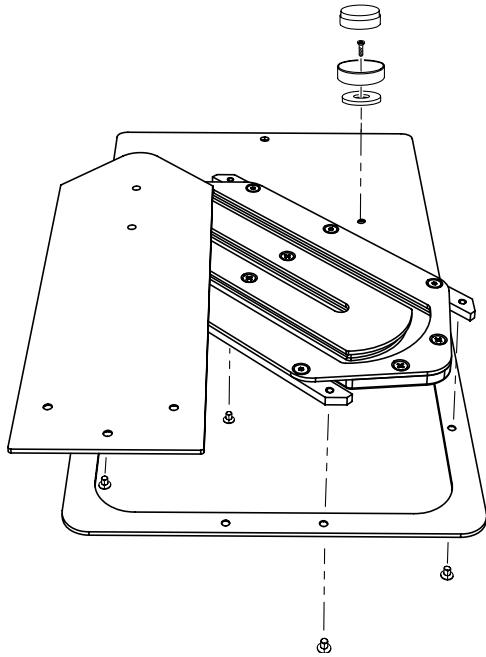

Option left opening

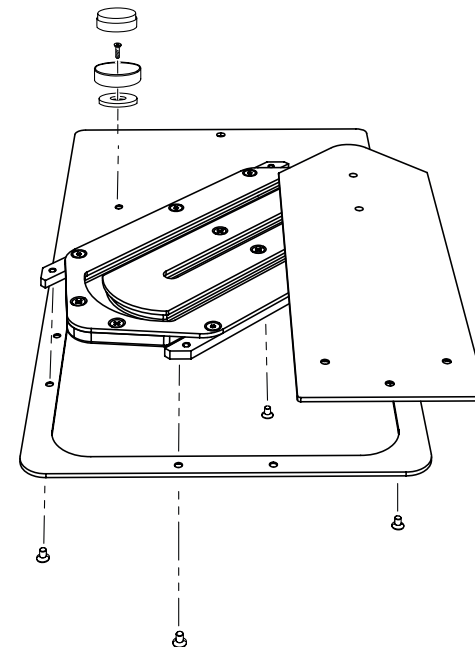

Option right opening

For right opening option take off felt glider cap and unscrew M4 screw from top. Then install round felt glider and space ring with M4 screw at the shown position. Put felt glider cap back on.

4. Install fixing screw

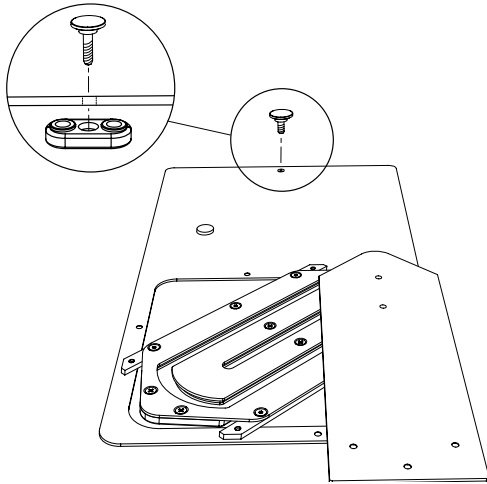

5. Insert slider into slider bar

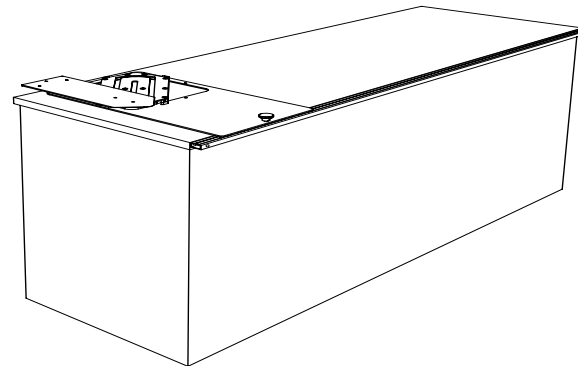
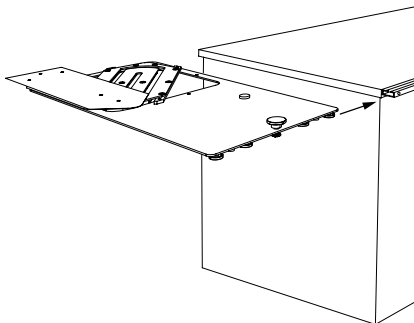

6. Install felt glider with wood screw 1x 4x10 mm

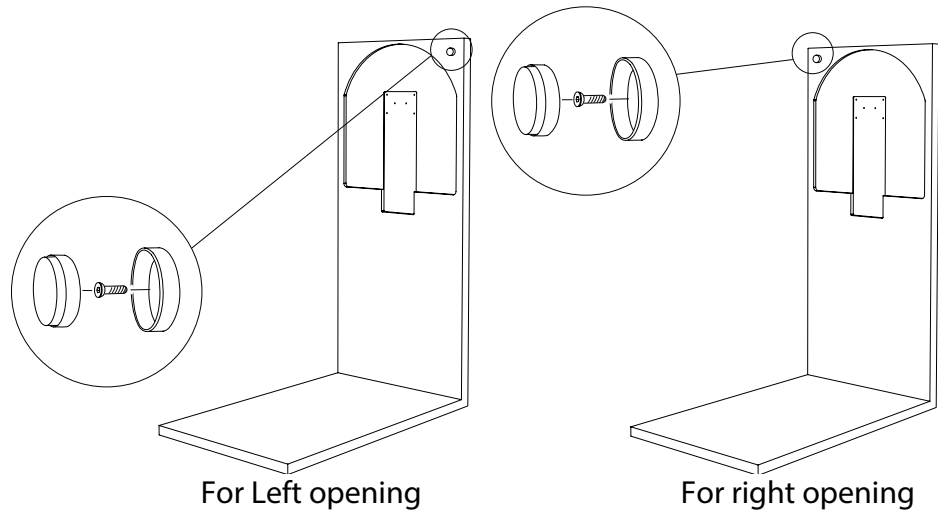

and locking plate into position in upper desk with 9x 5x 20 mm

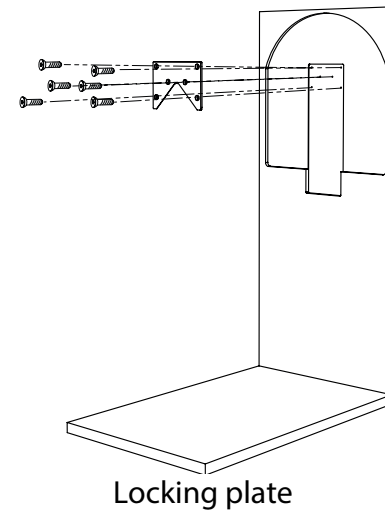

7. Install upper desk by hooking locking plate into mechanism, fix with 3x 5x 20 mm when in position

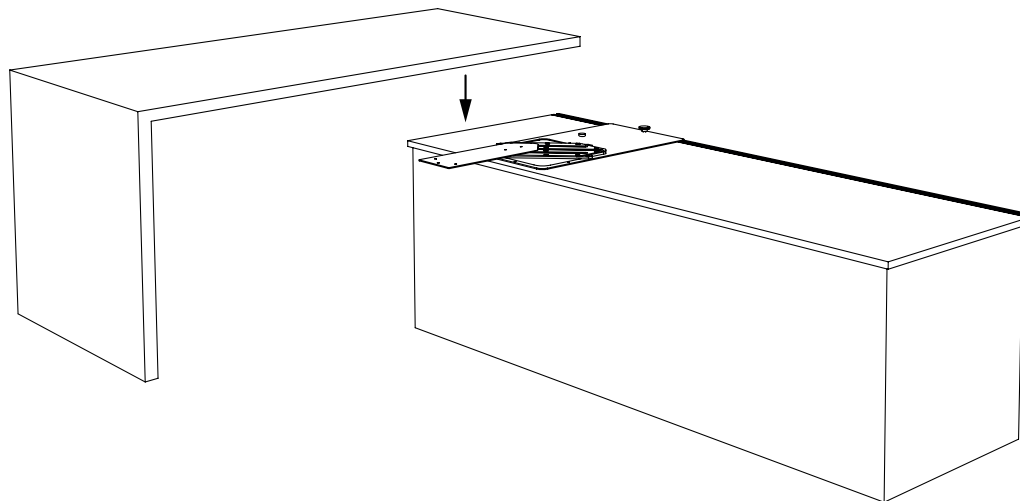

Turn your desk top upwards again and lift it over the furniture base. The desk should be moved in that way that the v-shape of the locking plate connects to the v-shape of the moveable plate of the CM4070 main mechanism. Pull the locking plate into the corresponding part of the moveable plate until they lock tight. Fix the screws into screw holes of the moveable plate underneath the desk. The desk is now ready for operation.

8. Install left and right stoppers in sliding bar

Slide 1 stopper set into the sliding bar from the left and 1 stopper set from the right.

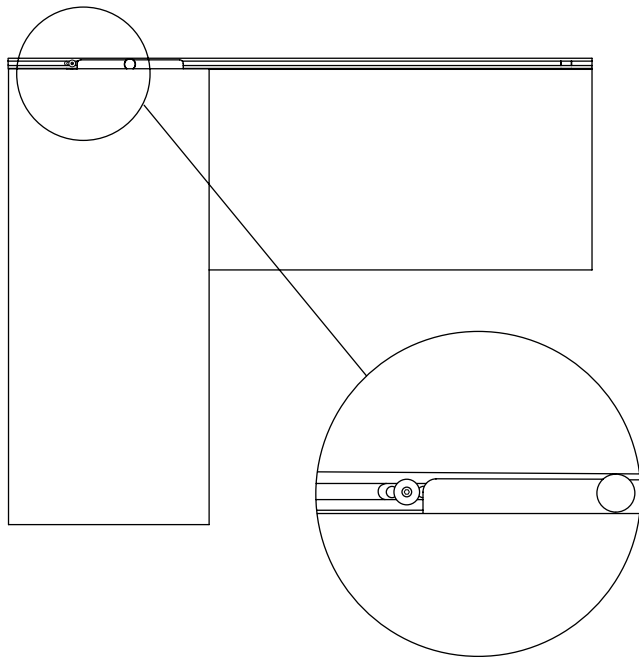
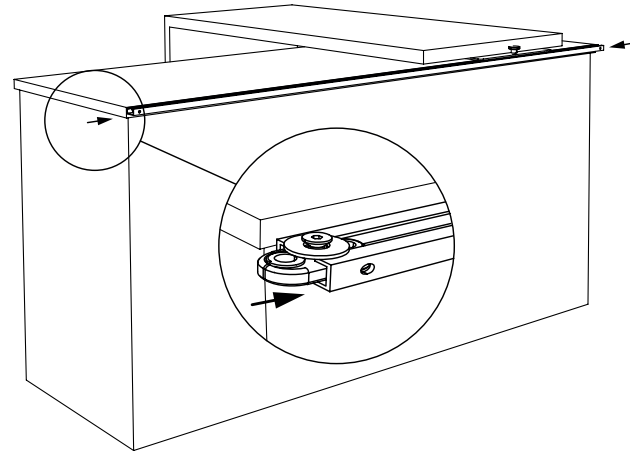

8.1 Move the upper desk to the left until the left side aligns with the furniture base on the left. Move the stopper towards the mechanism until a fix position is reached, tighten the screw.

8.2 Then move the upper desk to the right until the right side aligns with the furniture base on the right. Move the stopper towards the mechanism until a fix position is reached, tighten the screw.

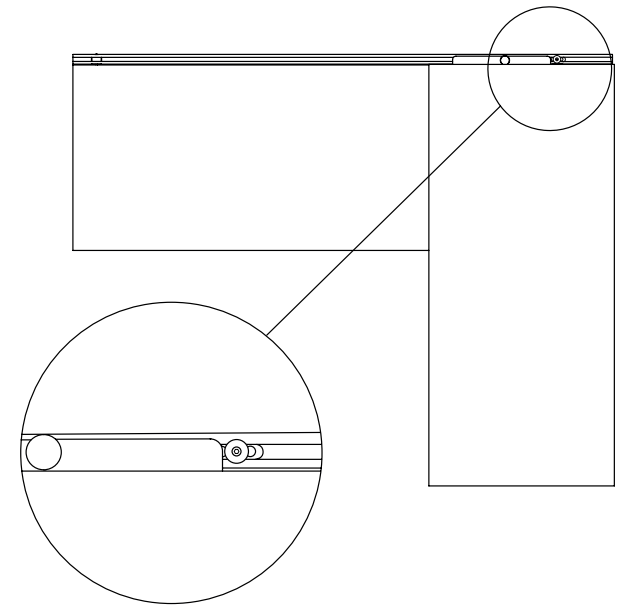

D) Operation of upper desk

Opening – before opening the upper desk, fasten the fixing screw to avoid sliding sideways of the upper desk

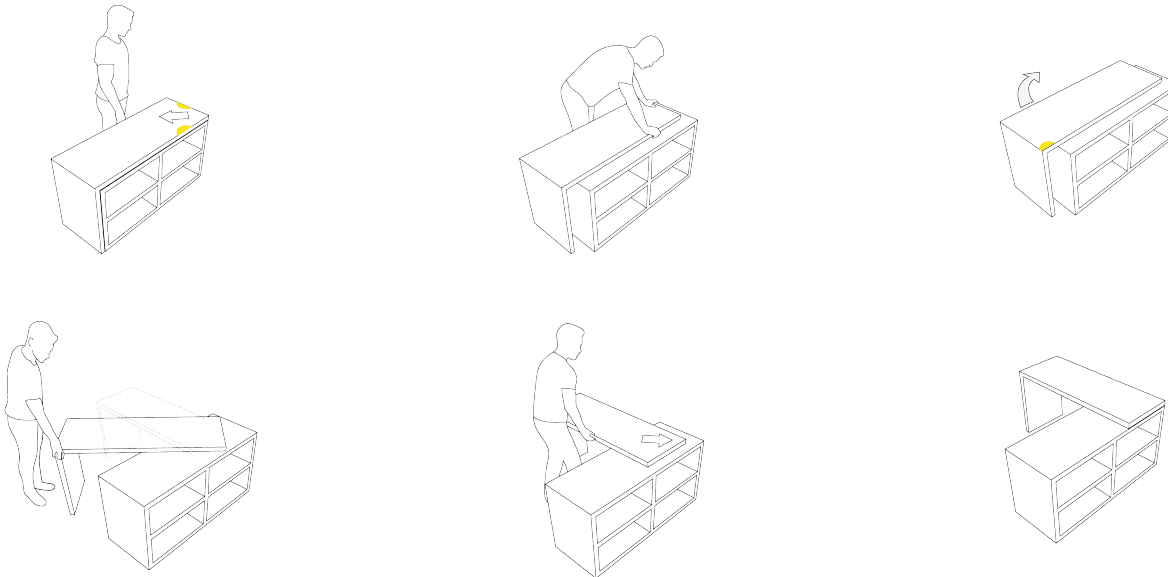

Sliding sideways in open position – when sliding the desk sideways, loosen the fixing screw before you start

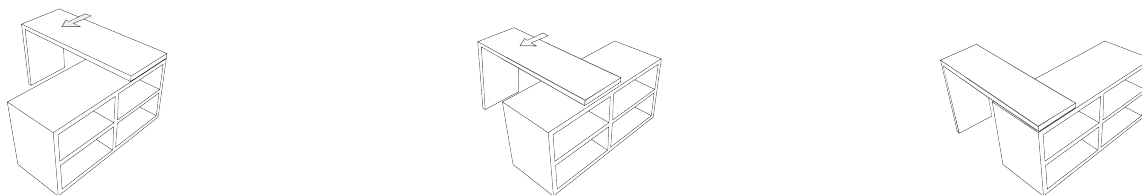

Closing – before closing the upper desk, fasten the fixing screw to avoid sliding sideways of the upper desk

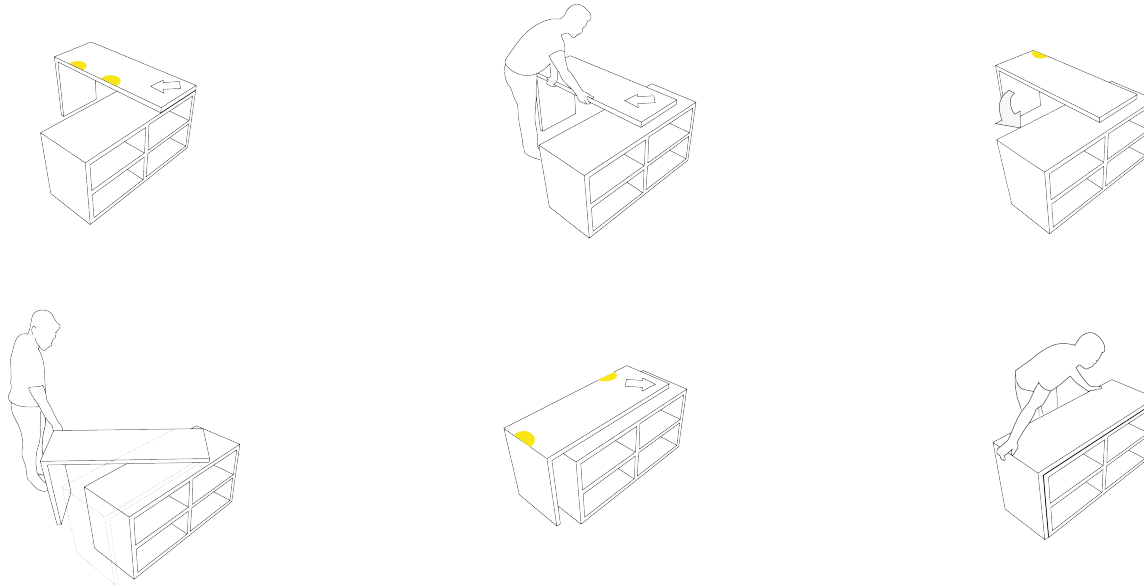

Sliding sideways in closed position – when sliding the desk sideways, loosen the fixing screw before you start

